

100 SERIES TRACK

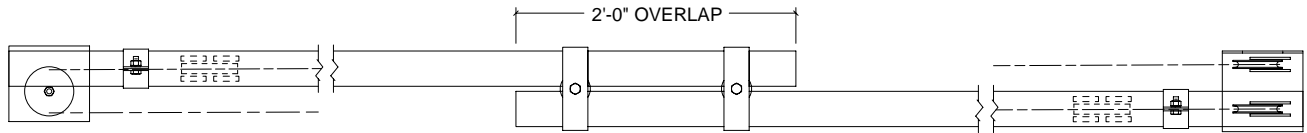

PLAN - MODEL 101S COMPLETE TRACK

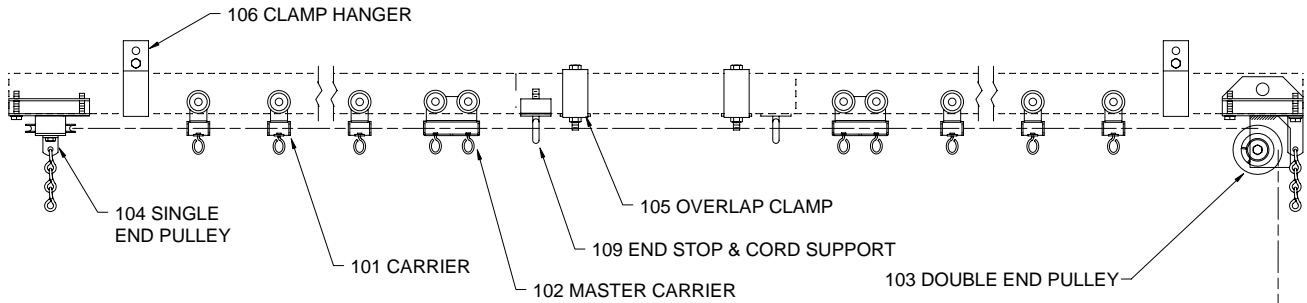

ELEVATION - MODEL 101S COMPLETE TRACK

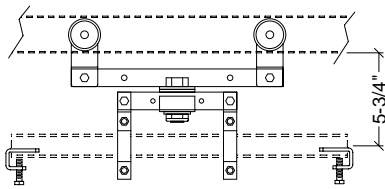

10 PIVOT DEVICE

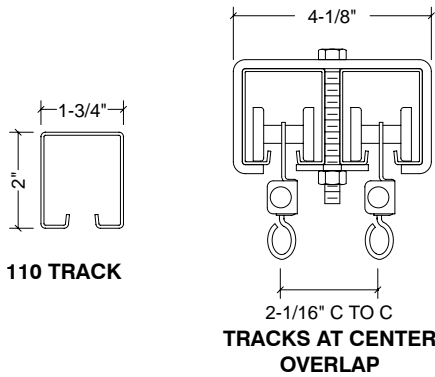
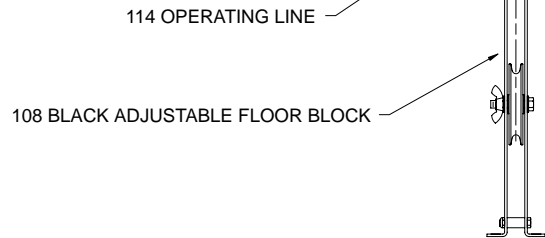

110 TRACK

TRACKS AT CENTER OVERLAP

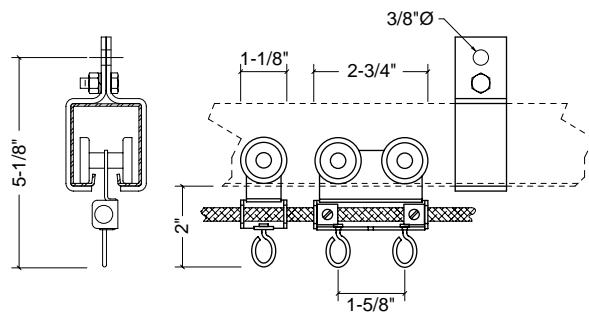

101 SINGLE CARRIER AND 102 MASTER CARRIER

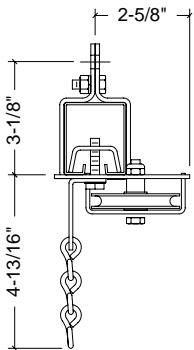

104 SINGLE END PULLEY

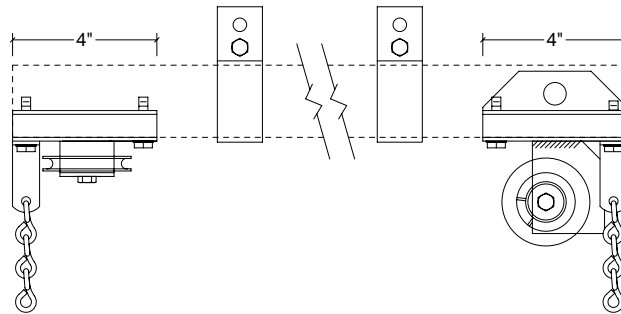

103 DOUBLE END PULLEY